



SCHLEGEL UK

Henlow Industrial Estate,
 Henlow Camp,
 Bedfordshire,
 SG16 6DS
 Tel: +44 (0) 1462 815500
 Fax: +44 (0) 1462 638800
 E-mail: schlegeluk@schlegel.eu.com

* Registered trademark of Schlegel Systems Inc.

Q-LON* 48510

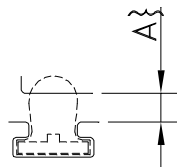
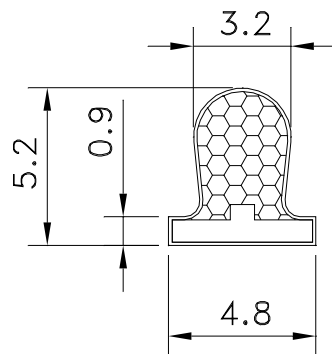

APPLICATION DETAILS

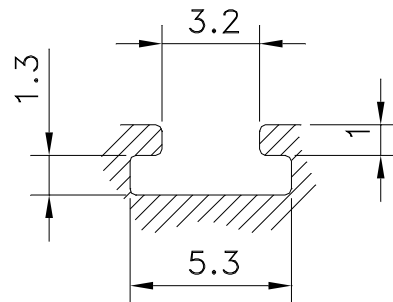

POCKET DETAILS

TECHNICAL SPECIFICATION
 A, SEAL GAP. 1.1mm MIN TO 2.4mm MAX

PART NUMBER	COLOUR	METRES/COIL	APPLICATION
02548510	WHITE	900	WEATHERSEAL
02548511	BLACK	900	WEATHERSEAL
02548512	WHITE	500	WEATHERSEAL
02548515	BLACK	100	WEATHERSEAL

60381-0A



BS7386 : 1990
 Licence NO. KM
 30928

Schlegel UK is a division of Schlegel Limited, Registration No. 3471668 Reg.
 Office : Hillside House, 32 Hampstead High St, London, NW3 1QD



Certification No.
 FM 15052