

Q-LON* 48750

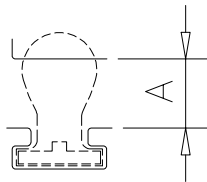
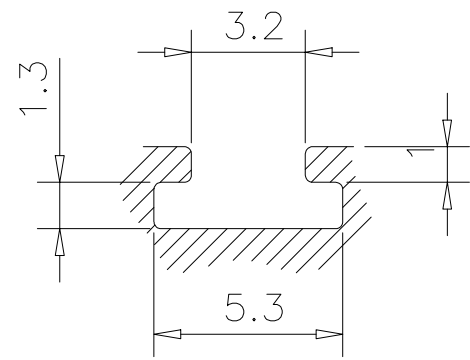
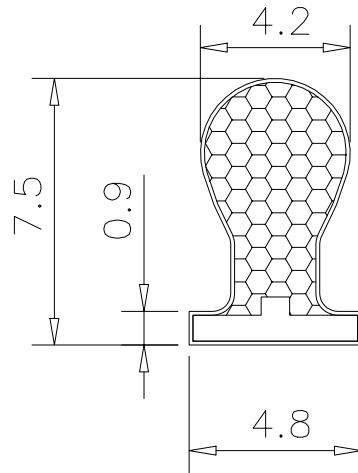

APPLICATION DETAILS

POCKET DETAILS

TECHNICAL SPECIFICATION
 A, SEAL GAP. 2.7mm MIN TO 4.6mm MAX

PART NUMBER	COLOUR	METRES/COIL	APPLICATION
02548750	WHITE	600	WEATHERSEAL
02548751	BLACK	600	WEATHERSEAL
02548752	BRONZE	600	WEATHERSEAL
02548753	BLACK	200	WEATHERSEAL