

Schlegel Weather Seal Range



Technical Data Sheet

Product = QLON / TSLOT for Aluminium Section

Testing undertaken to ISO 9001/2000; BSI Registration FM15052 (since 29/07/1992)

Specification			
Characteristic	Value	Units	Test Method
ACLD (Aged Compression Load Deflection)	7.0 –12.0 N/100mm	Neutons per 100mm length	In House
Compression Set	>20% set after 24hours (50% compression) @ 70°C	% Recovery mm	In House
Dimensions		mm	In House

Drawing Detail

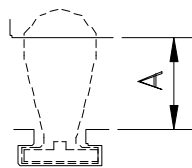
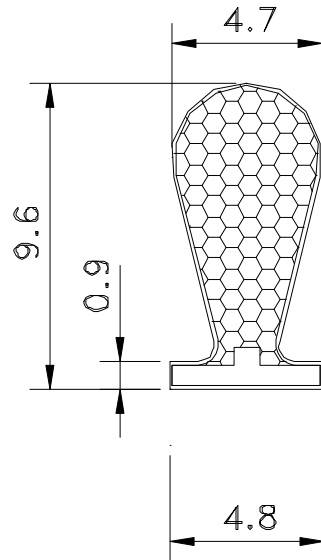

APPLICATION DETAILS

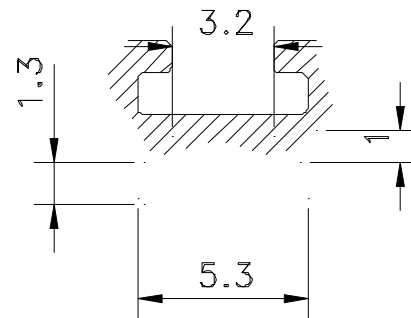

POCKET DETAILS

TECHNICAL SPECIFICATION
A, SEAL GAP. 4.0mm MIN TO 6.4mm MAX

UK

Schlegel UK, Henlow Industrial Estate, Henlow Camp, Bedfordshire, SG16 6DS

Phone: +44 1462 815500 Fax: +44 1462 811963

e:Mail: schlegeluk@schlegel.eu.com

Material / Components

Exterior Liner = Poly-ethylene
Exterior Liner Melt Index = approx. 0,85 g/10 min at 190 °C., 2,16 kg mass – 2.0MI
Hard Foot / insert = Poly-carbonate
Foam Core = H/R Poly-Urethane

Nominal Value of Thermal Conductivity

Low density P.E (used for the outer skin) is advised at 0.33 W/mKelvin
P.U.foam at a density of 70Kg / cubic mtr having a conductivity of 0.05 W/mKelvin

A proposed nominal value for all our seals = 0.06W/mKelvin.

Nominal Values for Sound Reduction Weighting

$R_w(C, C_{tr}) = 32$ (-1; -3)dB
 $R_w(C, C_{tr}) = 22$ (-1; -1)dB
 $R_w(C, C_{tr}) = 16$ (-1; 0)dB
 $R_w(C, C_{tr}) = 29$ (0; -2)dB

Packaging Specification

UK Card packing; 2 Coils per box; Nominal 200m / Coil

Coil = 825 OD – 425 ID; Box = 710*710*380mm

Part number detail

02548932	QL 48950	BLK 300M	CL	300
02548950	QL 48950	WHT 500M	CL	500
02548951	QL 48950	BLK 500M	CL	500
02548953	QL 48950	BLK 100M	CL	100
02548954	QL 48950	BLK 200M	CL	200
02548955	QL 48950	GRY 500M	CL	500
02548957	QL 48950	BLK 15M	CL	15
02548958	QL 48X950	BLK 200M SINGLE	CL	200
02548960	QL 48950	WHT 200M	CL	200
02548966	QL 48950	RAL GRY 200M	CL	200
02548970	QL 48950	WHT 150M	CL	150
02548972	QL 48950	BLK 150M	CL	150
02548986	QL 48950	RAL GRY 200	KBE CL	200
02548992	QL 48950	BLK 500M	CL	500

UK

Schlegel UK, Henlow Industrial Estate, Henlow Camp, Bedfordshire, SG16 6DS

Phone: +44 1462 815500 Fax: +44 1462 811963

e:Mail: schlegeluk@schlegel.eu.com

Corner Jointing

Seal section mitred at corners or butt jointed as required
Join seal with the application of Silicone Mastic sealant

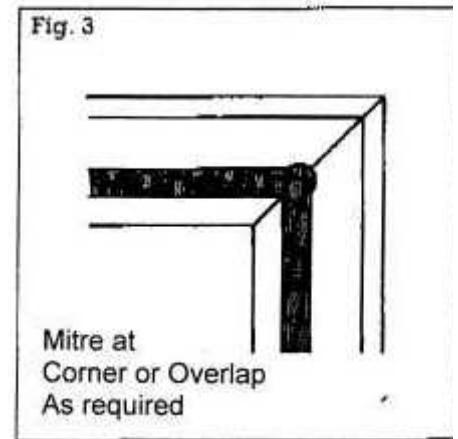
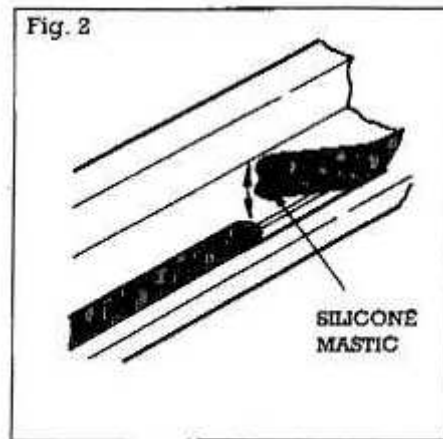
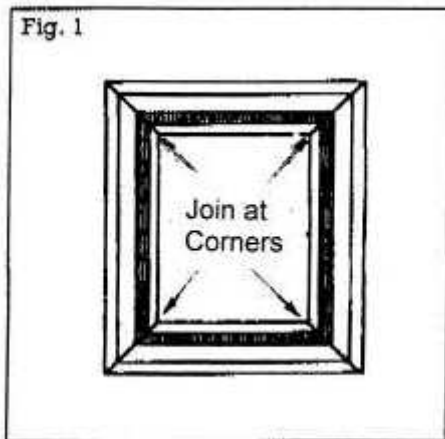

BBA Report

CRITERIA	B.B.A. 345/1 1993	B.B.A. Report 1990	Comments
TENSILE STRENGTH AFTER AGEING	< 25% REDUCTION AFTER 10 DAYS AT 70 ⁰ C	0% REDUCTION AFTER 28 DAYS	Q-Lon Exceeds the requirement
ELONGATION AT BREAK AFTER AGEING.	< 25% REDUCTION	> 5% REDUCTION AFTER 28 DAYS.	Q-Lon Exceeds the requirement
HARDNESS CHANGE AFTER AGEING	< 25% REDUCTION AFTER 10 DAYS AT 70 ⁰ C	COMPRESSION FORCE CHANGED BY 5% AFTER 28 DAYS	Q-Lon Exceeds the requirement
TEAR RESISTANCE	RAW MATERIAL TEST ONLY	NO ASSESSMENT	
DEFLECTION RECOVERY 24HRS @ 23 ⁰ C	> 75% RECOVERY	91.67% RECOVERY @ 70 ⁰ C	Q-Lon Exceeds the requirement
24hrs @ -15 ⁰ C	> 75% RECOVERY (LESS THAN 25% SET	100% RECOVERY	
14DAYS @ 55 ⁰ C	>25% RECOVERY	NOT ASSESSED	
OZONE RESISTANCE		NOT ASSESSED & NOT AFFECTED BY OZONE	This criteria is a limitation of Rubber / E.P.D.M.
DIMENSIONAL STABILITY	HEAT REVERSION < 2%	DIMENSIONAL STABILITY 0.01%	Q-Lon Exceeds the requirement

The B.P.F. have reviewed the 345/1 document and are shortly to publish a revision. The revisions take account of current European draft standards for seals and will most likely include the following changes.

1. Test methods will not be limited to raw material assessment.
2. The test methods will allow the seal performance to be graded as opposed to minimum levels being specified. The system is intended to allow an appropriate seal to be specified for an application. Minimum performances are still assessed via the functionality tests of the complete window / door unit.

UK

Schlegel UK, Henlow Industrial Estate, Henlow Camp, Bedfordshire, SG16 6DS

Phone: +44 1462 815500 Fax: +44 1462 811963

e:Mail: schlegeluk@schlegel.eu.com

Performance Benefits Summary

Excellent memory – Returns to original shape after compression

Stability – Low/no stretch gained by GF internal cord or insert

Easily compressed – Low compression forces, Unaffected by temp variance (tested to -30oC to +70oC)

Acoustic performance – Independent testing and comparison data available

Paint and Stain Proof – Properties un-affected by standard paints and stains

Stabilised – Unaffected by rot, Fungi, UV light or Ozone.

Colour – Wide range of available options (bronze, white, black, greys, etc)

Jointing – Can be joined with silicone sealant or welded in situ'

Patented.

UK

Schlegel UK, Henlow Industrial Estate, Henlow Camp, Bedfordshire, SG16 6DS

Phone: +44 1462 815500 Fax: +44 1462 811963

e:Mail: schlegeluk@schlegel.eu.com