



**SCHLEGEL UK**

Henlow Industrial Estate,  
 Henlow Camp,  
 Bedfordshire,  
 SG16 6DS  
 Tel: +44 (0) 1462 815500  
 Fax: +44 (0) 1462 638800  
 E-mail: schlegeluk@schlegel.eu.com

\* Registered trademark of Schlegel Systems Inc.

## Q-LON\* 5570

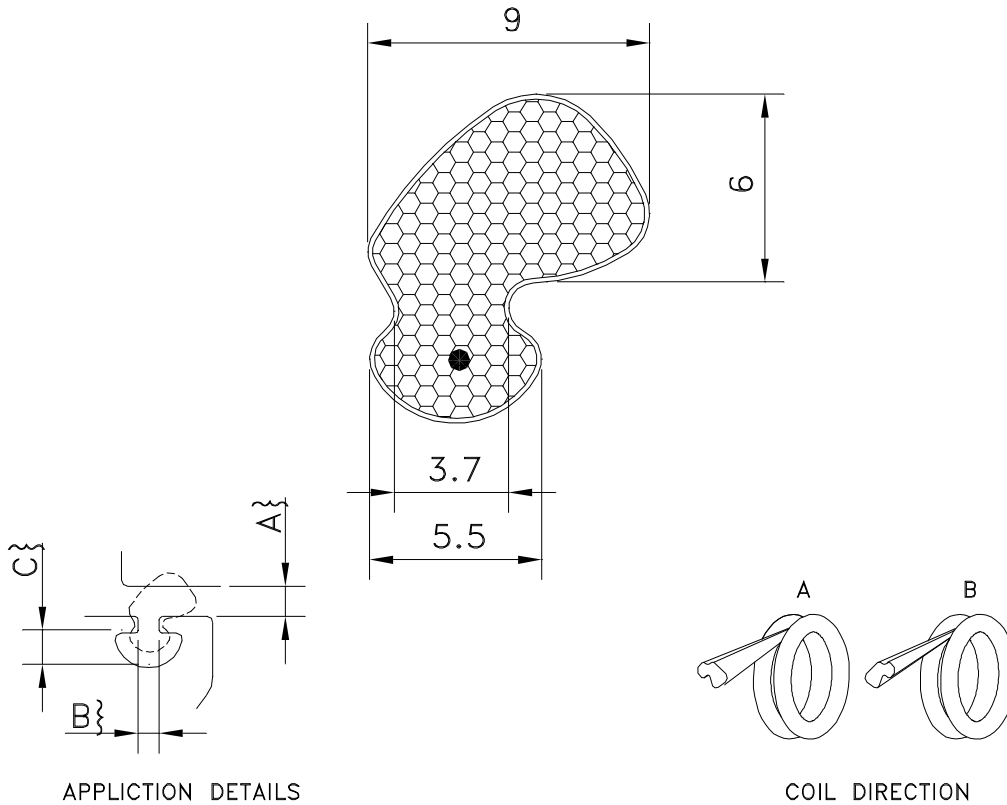

### TECHNICAL SPECIFICATION

- A, SEAL GAP. 3.0mm MIN TO 4.8mm MAX
- B, RETENTION SLOT THROAT. 3.3mm NOMINAL
- C, MINIMUM POCKET DEPTH 3.0mm

PART NUMBER	COLOUR	METRES/COIL	COIL DIRECTION	APPLICATION
02755700	WHITE	250	A	WEATHERSEAL
02755701	BRONZE	250	A	WEATHERSEAL
02755702	BLACK	250	A	WEATHERSEAL
02755730	WHITE	250	B	WEATHERSEAL
02755731	BRONZE	250	B	WEATHERSEAL
02755732	BLACK	250	B	WEATHERSEAL

60225-0B



BS7386 : 1990  
 Licence NO. KM  
 30928

Schlegel UK is a division of Schlegel Limited, Registratio n No. 3471668 Reg.  
 Office : Hillsgown House, 32 Hampstead High St, London, NW3 1QD



Certification No.  
 FM 15052